

# HEATLIGHT TECHNOLOGY

## HLP6000DSTS



The 6000DSTS model has six 1 KW Glare Control lamps, fitted into three twin cassettes.

Temperature is controlled through an optical electronic digital feedback loop which turns the heat up and down as required during the cycle.

The unit is equipped with a digital distance readout allowing it to be correctly positioned.

Lamps emit short wave infrared heat ideal for optimizing drying of waterborne paints.

This flexible system allows the cassettes to be adjusted and locked into position around the contours of the vehicle body, ensuring maximum area coverage.

Height adjustment is made using the high performance locking gas strut, offering a near weightless movement to the cassette support arm.

Typical drying cycle only costs 18 Pence (Based on 1Kw/hour of electricity costing 12 pence)

### Product features include

- 500mm 1Kw High output Glare Control short wave lamps fitted to each cassette.
- Specially designed electronic touch control panel allowing power, time and temperature control.
- Twin 30 minute programmable timers on both the Flash and Bake settings.
- Temperature settable on both Flash and Bake Cycle.
- Digital distance readout with safety cut out if unit is moved to close.
- Robust steel constructed stable frame, fitted with rear wheel locking castors.
- Maintenance free cassettes with no fan or filter changes.
- Individually switched cassettes.
- Horizontal or vertical cassette operation.
- When operating unit can display temperature or time remaining on Flash or Bake cycle.
- Long lamp/emitter life with an average of 6000hours. Typically 4 – 5 years continuous professional use.

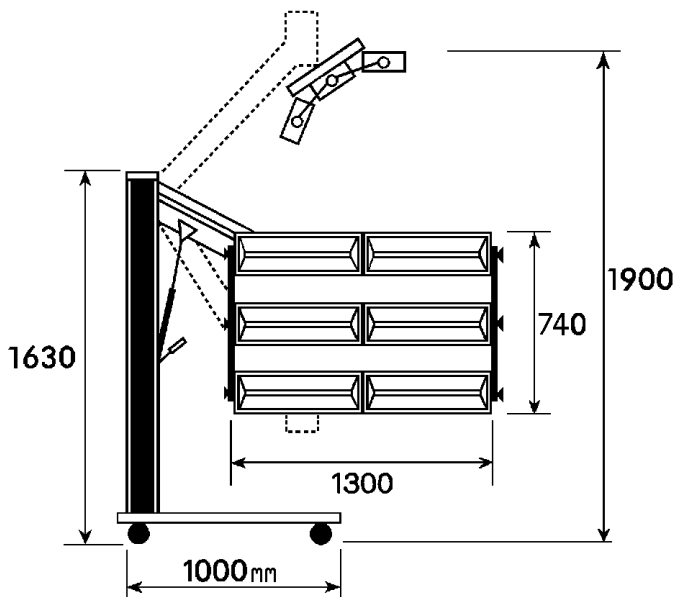

**Area coverage:- 2000mm x 1000mm**

Minimum operating distance:- 600mm

Max vertical curing height:- 2030mm

Max horizontal curing height:- 1800mm

Max curing temperature:- 80°C

### Average curing specification

Filler / Stopper:- 4 – 6 minutes

Primer:- 6 – 8 minutes

Top coat:- 10 – 12 minutes

### Electrical specification

220/240 Volt 6KW 50Hz single phase 25.00amps

380/415 Volt 6KW 50Hz 3 phase 8.33amps / phase

**HeatLight Technology**  
 Unit 36 Orbital 25 Business Park  
 Dwight Rd, Watford WD18 9DA UK  
 Tel: +44 (0) 1923 804080  
[www.heatlight.com](http://www.heatlight.com)  
 Email - [sales@heatlight.com](mailto:sales@heatlight.com)



Distributed by