

HEATLIGHT TECHNOLOGY

HLP4000DS



The 4000DS model has four 1 KW Glare Control lamps, fitted into four individual cassettes.

Unit is equipped with an ultrasonic distance indicator allowing it to be correctly positioned.

Lamps emit short wave infrared heat ideal for optimizing drying of waterborne paints.

This flexible system allows each cassette to be adjusted and locked into position around the contours of the vehicle body, ensuring maximum area coverage.

Height adjustment is made using the high performance locking gas strut, offering a near weightless movement to the cassette support arm.

Typical drying cycle only costs 12 Pence (Based on 1Kw/hour of electricity costing 12 pence)

Product features include

- 500mm 1Kw High output GC short wave lamps fitted to each cassette.
- Twin 30 minute timers on both the Flash and Bake settings.
- Power settable on both Flash and Bake Cycle.
- Distance indicator with safety cut out if unit is moved too close.
- Robust steel constructed stable frame, fitted with rear wheel locking castors.
- Maintenance free cassettes with no fan or filter changes.
- Individually switched cassettes.
- Horizontal or vertical cassette operation.
- Long lamp/emitter life with an average of 6000hours. Typically 4 – 5 years continuous professional use.

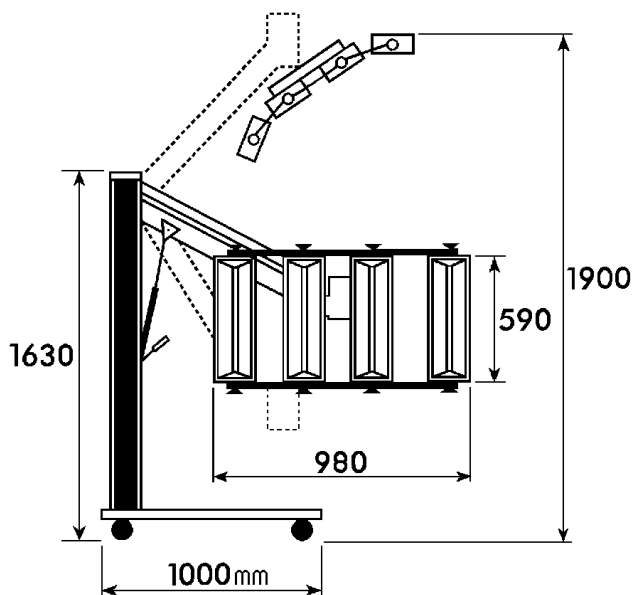

Area coverage:- 800mm x 1300mm
 Minimum operating distance:- 500mm
 Max vertical curing height:- 2030mm
 Max horizontal curing height:- 1800mm

Average curing specification

Filler / Stopper:- 4 – 6 minutes
 Primer:- 6 – 8 minutes
 Top coat:- 10 – 12 minutes

Electrical specification

220/240 Volt 4KW 50Hz single phase 17amps

HeatLight Technology
 Unit 36 Orbital 25 Business Park
 Dwight Rd, Watford WD18 9DA UK
 Tel: +44 (0) 1923 804080
www.heatlight.com
 Email - sales@heatlight.com



Distributed by